

PIM IGBT Module

电气特性:

- 1200V 沟槽栅/场终止工艺
- 低开关损耗
- 正温度系数

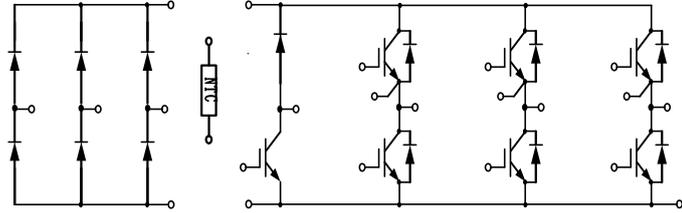

典型应用:

- 变频器
- 伺服
- 逆变器

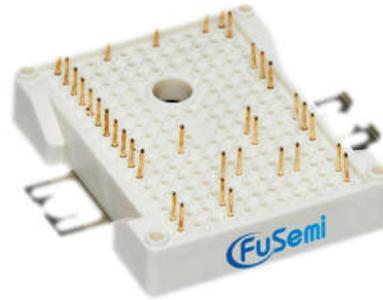

$V_{CES} = 1200V$, $I_{C\ nom} = 40A$ / $I_{CRM} = 80A$

IGBT, 逆变器 / IGBT, Inverter

最大额定值 / Maximum Ratings

Parameter	Conditions	Symbol	Value	Unit
集电极-发射极电压 Collector-Emitter voltage	$T_{vj} = 25^{\circ}C$	V_{CES}	1200	V
连续集电极直流电流 Continuous DC collector current	$T_C = 100^{\circ}C$, $T_{vj\ max} = 175^{\circ}C$	$I_{C\ nom}$	40	A
集电极重复峰值电流 Repetitive peak collector current	$t_p = 1\ ms$	I_{CRM}	80	A
总功率损耗 Total power dissipation	$T_C = 25^{\circ}C$, $T_{vj\ max} = 175^{\circ}C$	P_{tot}	200	W
栅极-发射极电压 Gate emitter voltage		V_{GE}	± 20	V

特征值 / Characteristic Values

Parameter	Conditions	Symbol	Value			Unit
			Min.	Typ.	Max.	
集电极-发射极饱和电压 Collector-Emitter saturation voltage	$V_{GE} = 15V$, $I_C = 40A$ $V_{GE} = 15V$, $I_C = 40A$ $V_{GE} = 15V$, $I_C = 40A$	$T_{vj} = 25^{\circ}C$ $T_{vj} = 125^{\circ}C$ $T_{vj} = 150^{\circ}C$	V_{CEsat}	2.11 2.52 2.67	2.55	V
栅极-发射极阈值电压 Gate-Emitter threshold voltage	$I_C = 1.5mA$, $V_{GE} = V_{CE}$	$T_{vj} = 25^{\circ}C$	$V_{GE(th)}$	5.20	5.80	6.40

内部栅极电阻 Internal gate resistor		R_{Gint}		5.60		Ω
输入电容 Input capacitance	$f=1\text{MHz}, V_{CE}=25\text{V}, V_{GE}=0\text{V}$	$T_{vj}=25^\circ\text{C}$	C_{ies}	2.49		nF
反向传输电容 Reverse transfer capacitance			C_{res}	0.11		
集电极-发射极截止电流 Collector-emitter cut-off current	$V_{CE}=1200\text{V}, V_{GE}=0\text{V}$	$T_{vj}=25^\circ\text{C}$	I_{CES}		1	mA
栅极-发射极漏电流 Gate-emitter leakage current	$V_{CE}=0\text{V}, V_{GE}=20\text{V}$	$T_{vj}=25^\circ\text{C}$	I_{GES}		100	nA
开通延迟时间 Turn-on delay time	$I_C=40\text{A}, V_{CE}=600\text{V}$ $V_{GE}=\pm 15\text{V}, R_G=12\Omega$ (电感负载) / (inductive load)	$T_{vj}=25^\circ\text{C}$ $T_{vj}=125^\circ\text{C}$ $T_{vj}=150^\circ\text{C}$	t_{don}		48	
					62	
					66	
上升时间 Rise time	$I_C=40\text{A}, V_{CE}=600\text{V}$ $V_{GE}=\pm 15\text{V}, R_G=12\Omega$ (电感负载) / (inductive load)	$T_{vj}=25^\circ\text{C}$ $T_{vj}=125^\circ\text{C}$ $T_{vj}=150^\circ\text{C}$	t_r		27	ns
					28	
					28	
关断延迟时间 Turn-off delay time	$I_C=40\text{A}, V_{CE}=600\text{V}$ $V_{GE}=\pm 15\text{V}, R_G=12\Omega$ (电感负载) / (inductive load)	$T_{vj}=25^\circ\text{C}$ $T_{vj}=125^\circ\text{C}$ $T_{vj}=150^\circ\text{C}$	t_{doff}		198	
					244	
					258	
下降时间 Fall time	$I_C=40\text{A}, V_{CE}=600\text{V}$ $V_{GE}=\pm 15\text{V}, R_G=12\Omega$ (电感负载) / (inductive load)	$T_{vj}=25^\circ\text{C}$ $T_{vj}=125^\circ\text{C}$ $T_{vj}=150^\circ\text{C}$	t_f		200	
					261	
					306	
开通损耗能量 (每脉冲) Turn-on energy loss per pulse	$I_C=40\text{A}, V_{CE}=600\text{V}$ $V_{GE}=\pm 15\text{V}, R_G=12\Omega$ (电感负载) / (inductive load)	$T_{vj}=25^\circ\text{C}$ $T_{vj}=125^\circ\text{C}$ $T_{vj}=150^\circ\text{C}$	E_{on}		1.70	mJ
					3.30	
					3.78	
关断损耗能量 (每脉冲) Turn-off energy loss per pulse	$I_C=40\text{A}, V_{CE}=600\text{V}$ $V_{GE}=\pm 15\text{V}, R_G=12\Omega$ (电感负载) / (inductive load)	$T_{vj}=25^\circ\text{C}$ $T_{vj}=125^\circ\text{C}$ $T_{vj}=150^\circ\text{C}$	E_{off}		2.32	
					3.20	
					3.48	
短路数据 SC data	$V_{GE}\leq 15\text{V}, V_{CC}=800\text{V}$ $V_{CEmax}=V_{CES}-L_{sCE}\cdot di/dt$	$t_p\leq 10\mu\text{s}, T_{vj}=150^\circ\text{C}$	I_{sc}		120	A
结-外壳热阻 Thermal resistance, junction to case	每个 IGBT / per IGBT		R_{thJC}		0.75	K/W
在开关状态下温度 Temperature under switching conditions			$T_{vj op}$	-40	150	$^\circ\text{C}$

二极管, 逆变器 / Diode, Inverter

最大额定值 / Maximum Ratings

Parameter	Conditions	Symbol	Value	Unit
反向重复峰值电压 Repetitive peak reverse voltage	$T_{vj}=25^\circ\text{C}$	V_{RRM}	1200	V
连续正向直流电流 Continuous DC forward current		I_F	40	A
正向重复峰值电流 Repetitive peak forward current	$t_p=1\text{ms}$	I_{FRM}	80	A
I^2t 值 I^2t -value	$t_p=10\text{ms}, \sin 180^\circ, T_{vj}=125^\circ\text{C}$	I^2t	1560	A^2s

特征值 / Characteristic Values

Parameter	Conditions	Symbol	Value			Unit
			Min.	Typ.	Max.	
正向电压 Forward voltage	$I_F=40A, V_{GE}=0V$ $I_F=40A, V_{GE}=0V$ $I_F=40A, V_{GE}=0V$	$T_{vj}=25^{\circ}C$ $T_{vj}=125^{\circ}C$ $T_{vj}=150^{\circ}C$	V_F		2.40 2.10 2.03	2.90 V
反向恢复峰值电流 Peak reverse recovery current	$I_F=40A,$ $-di_F/dt=902A/\mu s(T_{vj}=150^{\circ}C)$ $V_R=600V, V_{GE}=-15V$	$T_{vj}=25^{\circ}C$ $T_{vj}=125^{\circ}C$ $T_{vj}=150^{\circ}C$	I_{RM}		30 40 42	A
恢复电荷 Recovered charge	$I_F=40A,$ $-di_F/dt=902A/\mu s(T_{vj}=150^{\circ}C)$ $V_R=600V, V_{GE}=-15V$	$T_{vj}=25^{\circ}C$ $T_{vj}=125^{\circ}C$ $T_{vj}=150^{\circ}C$	Q_f		3.20 7.30 8.70	μC
反向恢复损耗（每脉冲） Reverse recovered energy	$I_F=40A,$ $-di_F/dt=902A/\mu s(T_{vj}=150^{\circ}C)$ $V_R=600V, V_{GE}=-15V$	$T_{vj}=25^{\circ}C$ $T_{vj}=125^{\circ}C$ $T_{vj}=150^{\circ}C$	E_{rec}		0.68 2.66 3.12	mJ
结-外壳热阻 Thermal resistance, junction to case	每个 Diode / per diode					1.20 K/W
在开关状态下温度 Temperature under switching conditions			$T_{vj\ op}$	-40		150 $^{\circ}C$

二极管，整流器 / Diode, Rectifier

最大额定值 / Maximum Ratings

Parameter	Conditions	Symbol	Value	Unit
反向重复峰值电压 Repetitive peak reverse voltage	$T_{vj}=25^{\circ}C$	V_{RRM}	1600	V
反向不重复峰值电压 Non-Repetitive peak reverse voltage	$T_{vj}=25^{\circ}C, I_{RRM}=5\mu A$	V_{RSM}	2000	V
最大正向平均电流 Maximum Average Forward Current		$I_{F(AV)}$	30	A
正向浪涌电流 Surge forward current	$t_p=10ms, \sin 180^{\circ}, T_{vj}=25^{\circ}C$	I_{FSM}	360	A
I^2t 值 I^2t -value	$t_p=10ms, \sin 180^{\circ}, T_{vj}=125^{\circ}C$	I^2t	648	A^2s

特征值 / Characteristic Values

Parameter	Conditions	Symbol	Value			Unit
			Min.	Typ.	Max.	
正向电压 Forward voltage	$I_F=30A, T_j=25^{\circ}C$	V_F			1.2	V
反向电流 Reverse current	$V_R=V_{RRM}$ $T_{vj}=25^{\circ}C$	I_R			5	μA

在开关状态下温度 Temperature under switching conditions		$T_{vj\ op}$	-40		150	°C
--	--	--------------	-----	--	-----	----

IGBT，制动-斩波器 / IGBT, Brake-Chopper

最大额定值 / Maximum Ratings

Parameter	Conditions	Symbol	Value	Unit
集电极-发射极电压 Collector-Emitter voltage	$T_{vj}=25^{\circ}\text{C}$	V_{CES}	1200	V
连续集电极直流电流 Continuous DC collector current	$T_C=100^{\circ}\text{C}, T_{vj\ max}=175^{\circ}\text{C}$	$I_{C\ nom}$	25	A
集电极重复峰值电流 Repetitive peak collector current	$t_p=1\ ms$	I_{CRM}	50	A
总功率损耗 Total power dissipation	$T_C = 25^{\circ}\text{C}, T_{vj\ max} = 175^{\circ}\text{C}$	P_{tot}	125	W
栅极-发射极电压 Gate emitter voltage		V_{GE}	± 20	V

特征值 / Characteristic Values

Parameter	Conditions	Symbol	Value			Unit
			Min.	Typ.	Max.	
集电极-发射极饱和电压 Collector-Emitter saturation voltage	$V_{GE}=15\text{V}, I_C=25\text{A}$ $V_{GE}=15\text{V}, I_C=25\text{A}$ $V_{GE}=15\text{V}, I_C=25\text{A}$	$T_{vj}=25^{\circ}\text{C}$ $T_{vj}=125^{\circ}\text{C}$ $T_{vj}=150^{\circ}\text{C}$	V_{CESat}	2.06 2.48 2.61	2.50	V
栅极-发射极阈值电压 Gate-Emitter threshold voltage	$I_C=1\text{mA}, V_{GE}=V_{CE}$	$T_{vj}=25^{\circ}\text{C}$	$V_{GE(th)}$	5.20 5.80	6.40	
内部栅极电阻 Internal gate resistor			R_{Gint}	None		Ω
输入电容 Input capacitance	$f=1\text{MHz}, V_{CE}=25\text{V}, V_{GE}=0\text{V}$	$T_{vj}=25^{\circ}\text{C}$	C_{ies}	0.15		nF
反向传输电容 Reverse transfer capacitance			C_{res}	0.06		
集电极-发射极截止电流 Collector-emitter cut-off current	$V_{CE}=1200\text{V}, V_{GE}=0\text{V}$	$T_{vj}=25^{\circ}\text{C}$	I_{CES}		1.0	mA
栅极-发射极漏电流 Gate-emitter leakage current	$V_{CE}=0\text{V}, V_{GE}=20\text{V}$	$T_{vj}=25^{\circ}\text{C}$	I_{GES}		100	nA
开通延迟时间 Turn-on delay time	$I_C=25\text{A}, V_{CE}=600\text{V}$ $V_{GE}=\pm 15\text{V}, R_G=68\Omega$ (电感负载) / (inductive load)	$T_{vj}=25^{\circ}\text{C}$ $T_{vj}=125^{\circ}\text{C}$ $T_{vj}=150^{\circ}\text{C}$	$t_{d\ on}$	84 81 76		ns
上升时间 Rise time	$I_C=25\text{A}, V_{CE}=600\text{V}$ $V_{GE}=\pm 15\text{V}, R_G=68\Omega$ (电感负载) / (inductive load)	$T_{vj}=25^{\circ}\text{C}$ $T_{vj}=125^{\circ}\text{C}$ $T_{vj}=150^{\circ}\text{C}$	t_r	51 61 60		
关断延迟时间 Turn-off delay time	$I_C=25\text{A}, V_{CE}=600\text{V}$ $V_{GE}=\pm 15\text{V}, R_G=68\Omega$ (电感负载) / (inductive load)	$T_{vj}=25^{\circ}\text{C}$ $T_{vj}=125^{\circ}\text{C}$ $T_{vj}=150^{\circ}\text{C}$	$t_{d\ off}$	264 298 304		
下降时间 Fall time	$I_C=25\text{A}, V_{CE}=600\text{V}$	$T_{vj}=25^{\circ}\text{C}$	t_f	203		

Fall time	$V_{GE}=\pm 15\text{ V}$, $R_G=68\Omega$ (电感负载) / (inductive load)	$T_{vj}=125^\circ\text{C}$ $T_{vj}=150^\circ\text{C}$			297 283		
开通损耗能量 (每脉冲) Turn-on energy loss per pulse	$I_C=25\text{ A}$, $V_{CE}=600\text{ V}$ $V_{GE}=\pm 15\text{ V}$, $R_G=68\Omega$ (电感负载) / (inductive load)	$T_{vj}=25^\circ\text{C}$ $T_{vj}=125^\circ\text{C}$ $T_{vj}=150^\circ\text{C}$	E_{on}		2.54 4.13 4.51		mJ
关断损耗能量 (每脉冲) Turn-off energy loss per pulse	$I_C=25\text{ A}$, $V_{CE}=600\text{ V}$ $V_{GE}=\pm 15\text{ V}$, $R_G=68\Omega$ (电感负载) / (inductive load)	$T_{vj}=25^\circ\text{C}$ $T_{vj}=125^\circ\text{C}$ $T_{vj}=150^\circ\text{C}$	E_{off}		1.48 1.95 2.09		
短路数据 SC data	$V_{GE}\leq 15\text{ V}$, $V_{CC}=800\text{ V}$ $V_{CEmax}=V_{CES}-L_{sCE}\cdot di/dt$ $t_p\leq 10\mu\text{s}$, $T_{vj}=150^\circ\text{C}$		I_{SC}		73		A
结-外壳热阻 Thermal resistance, junction to case	每个 IGBT / per IGBT		R_{thJC}			1.20	K/W
在开关状态下温度 Temperature under switching conditions			$T_{vj\ op}$	-40		150	$^\circ\text{C}$

二极管, 制动-斩波器 / Diode, Brake-Chopper

最大额定值 / Maximum Ratings

Parameter	Conditions	Symbol	Value	Unit
反向重复峰值电压 Repetitive peak reverse voltage	$T_{vj}=25^\circ\text{C}$	V_{RRM}	1200	V
连续正向直流电流 Continuous DC forward current		I_F	10	A
正向重复峰值电流 Repetitive peak forward current	$t_p=1\text{ ms}$	I_{FRM}	20	A
I^2t 值 I^2t -value	$t_p=10\text{ ms}$, $\sin 180^\circ$, $T_{vj}=125^\circ\text{C}$	I^2t	120	A^2s

特征值 / Characteristic Values

Parameter	Conditions	Symbol	Value			Unit	
			Min.	Typ.	Max.		
正向电压 Forward voltage	$I_F=10\text{ A}$, $V_{GE}=0\text{ V}$ $I_F=10\text{ A}$, $V_{GE}=0\text{ V}$ $I_F=10\text{ A}$, $V_{GE}=0\text{ V}$	$T_{vj}=25^\circ\text{C}$ $T_{vj}=125^\circ\text{C}$ $T_{vj}=150^\circ\text{C}$	V_F		1.81 1.38 1.29	2.30 V	
反向恢复峰值电流 Peak reverse recovery current	$I_F=10\text{ A}$, $-di_F/dt=356\text{ A}/\mu\text{s}$ ($T_{vj}=150^\circ\text{C}$) $V_R=600\text{ V}$, $V_{GE}=-15\text{ V}$	$T_{vj}=25^\circ\text{C}$ $T_{vj}=125^\circ\text{C}$ $T_{vj}=150^\circ\text{C}$	I_{RM}		10 16 17	A	
恢复电荷 Recovered charge	$I_F=10\text{ A}$, $-di_F/dt=356\text{ A}/\mu\text{s}$ ($T_{vj}=150^\circ\text{C}$) $V_R=600\text{ V}$, $V_{GE}=-15\text{ V}$	$T_{vj}=25^\circ\text{C}$ $T_{vj}=125^\circ\text{C}$ $T_{vj}=150^\circ\text{C}$	Q_F		0.90 2.40 2.90	μC	
反向恢复损耗 (每脉冲) Reverse recovered energy	$I_F=10\text{ A}$, $-di_F/dt=356\text{ A}/\mu\text{s}$ ($T_{vj}=150^\circ\text{C}$) $V_R=600\text{ V}$, $V_{GE}=-15\text{ V}$	$T_{vj}=25^\circ\text{C}$ $T_{vj}=125^\circ\text{C}$ $T_{vj}=150^\circ\text{C}$	E_{rec}		0.29 0.75 0.92	mJ	
结-外壳热阻 Thermal resistance, junction to case	每个 Diode / per diode		R_{thJC}			1.90	K/W

在开关状态下温度 Temperature under switching conditions		$T_{vj\ op}$	-40		150	°C
--	--	--------------	-----	--	-----	----

负温度系数热敏电阻 / NTC-Thermistor

特征值 / Characteristic Values

Parameter	Conditions	Symbol	Value			Unit
			Min.	Typ.	Max.	
额定电阻值 Rated resistances	$T_c=25^\circ\text{C}$, $\pm 5\%$	R_{25}		5.0		K Ω
B-值 B-value	$\pm 2\%$	$B_{25/50}$		3375		K

模块 / Module

Parameter	Conditions	Symbol	Value			Unit
绝缘测试电压 Isolation test voltage	RMS, f=50Hz, t=1min	V_{ISOL}	2500			V
内部绝缘 Internal isolation			Al_2O_3			
储存温度 Storage temperature		T_{stg}	-40		125	°C
模块安装的扭矩 Mounting torque for modul mounting		M	3.0		6.0	Nm
重量 Weight		W		42		g



图 1. 典型输出特性 ($V_{GE}=15V$)

Figure 1. Typical output characteristics ($V_{GE}=15V$)

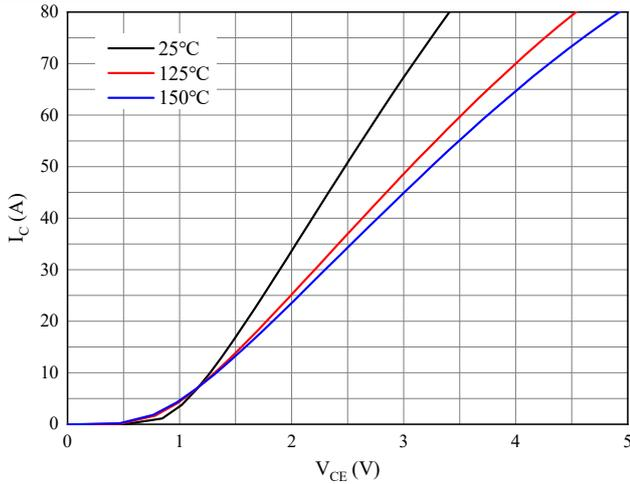

图 2. 典型输出特性 ($T_{vj}=150^{\circ}C$)

Figure 2. Typical output characteristics ($T_{vj}=150^{\circ}C$)

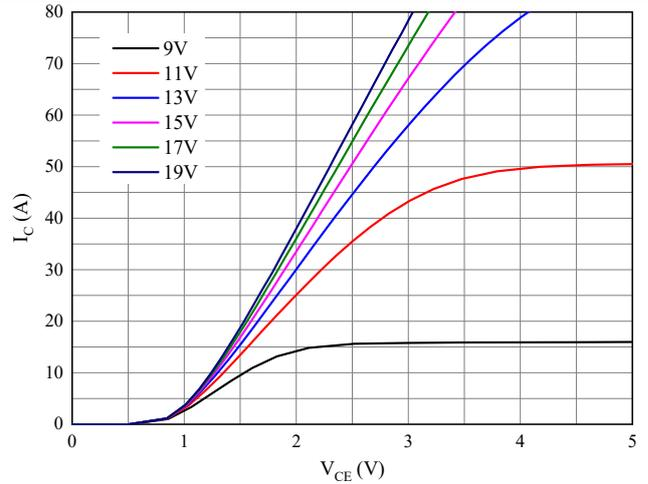

图 3. 典型传输特性 ($V_{CE}=20V$)

Figure 3. Typical transfer characteristic ($V_{CE}=20V$)

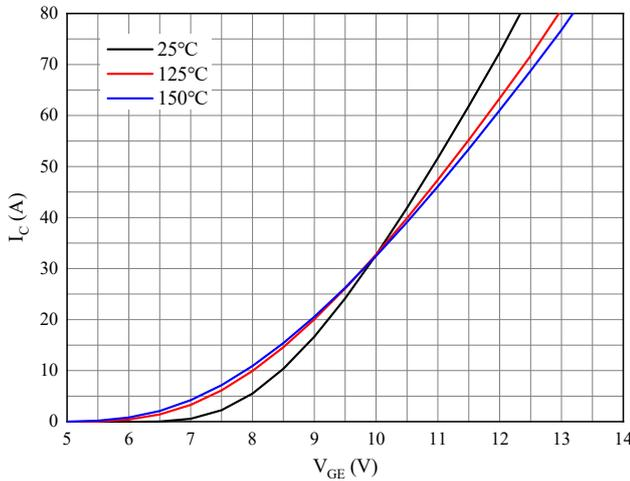

图 4. 正向偏压特性 二极管

Figure 4. Forward characteristic of Diode

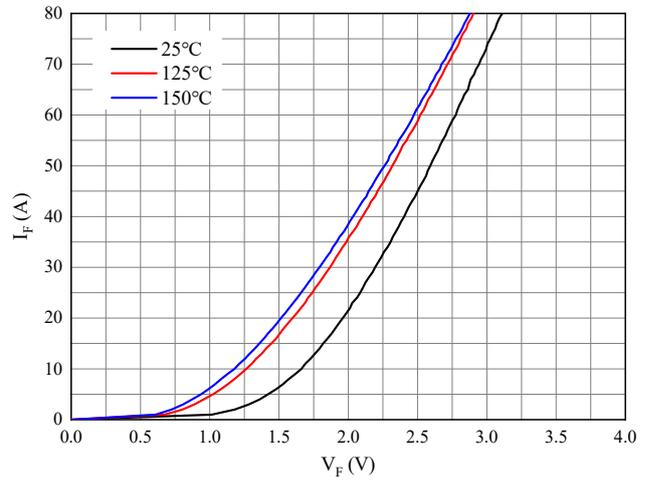

图 5. 开关损耗 逆变器

Figure 5. Switching losses of IGBT
 $V_{GE}=\pm 15V, R_{Gon}=12\Omega, R_{Goff}=12\Omega, V_{CE}=600V$

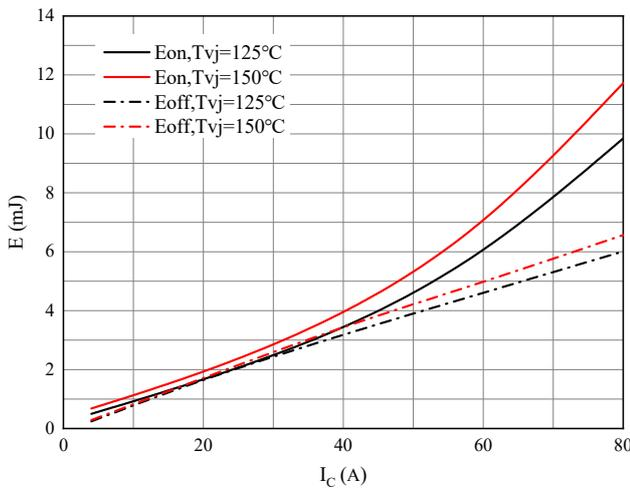

图 6. 开关损耗 逆变器

Figure 6. Switching losses of IGBT
 $V_{GE}=\pm 15V, I_C=40A, V_{CE}=600V$

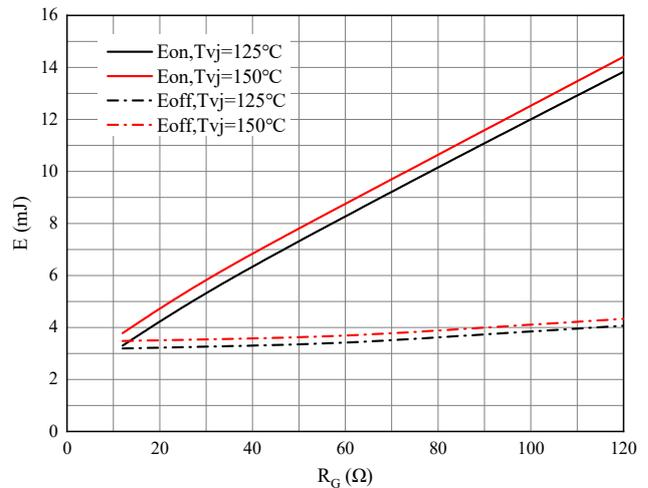

图 7. 开关损耗 二极管

Figure 7. Switching losses of Diode
R_{Gon}=12Ω, V_{CE}=600V

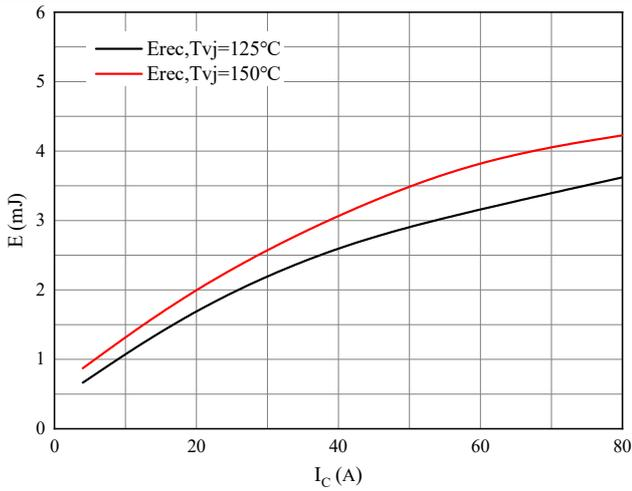

图 8. 开关损耗 二极管

Figure 8. Switching losses of Diode
I_F=40A, V_{CE}=600V

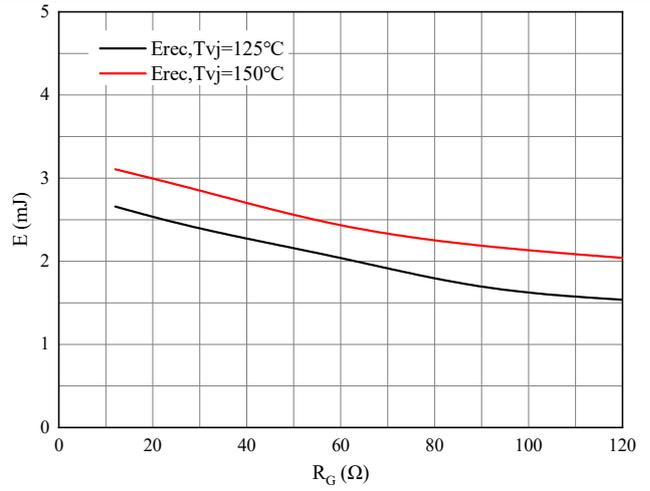

图 9. 电容特性

Figure 9. Capacitance characteristic

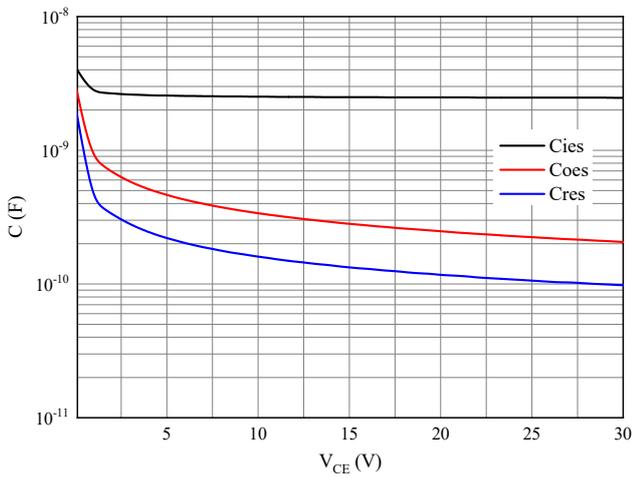

图 10. 负温系数热敏电阻 温度特性

Figure 10. NTC-Themistor-temperature characteristic

接线图 / Circuit diagram

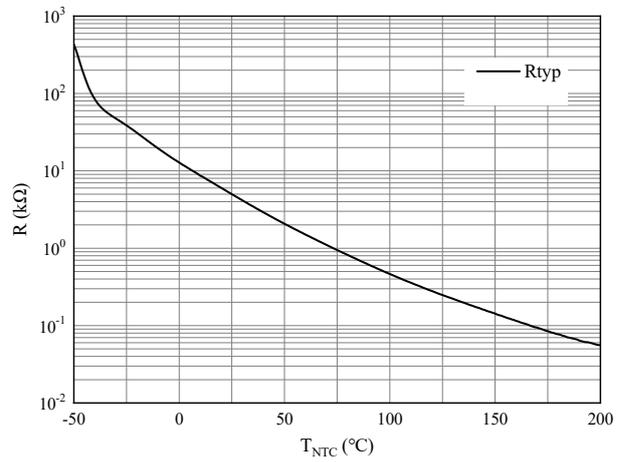
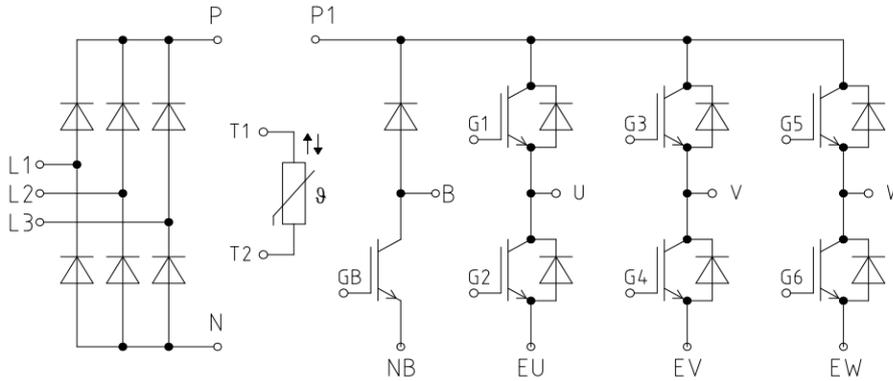

封装尺寸 / Package outlines

