

PIM IGBT Module

电气特性:

- 1200V 沟槽栅/场终止工艺
- 低开关损耗
- 正温度系数

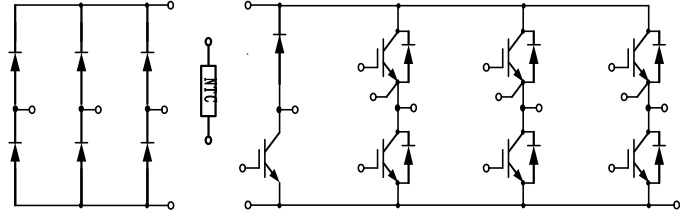

典型应用:

- 变频器
- 伺服
- 逆变器



$V_{CES} = 1200V$, $I_{C\ nom} = 40A$ / $I_{CRM} = 80A$

IGBT, 逆变器 / IGBT, Inverter

最大额定值 / Maximum Ratings

Parameter	Conditions	Symbol	Value	Unit
集电极-发射极电压 Collector-Emitter voltage	$T_{vj} = 25^{\circ}C$	V_{CES}	1200	V
连续集电极直流电流 Continuous DC collector current	$T_C = 100^{\circ}C$, $T_{vj\ max} = 175^{\circ}C$	$I_{C\ nom}$	40	A
集电极重复峰值电流 Repetitive peak collector current	$t_p = 1\ ms$	I_{CRM}	80	A
栅极-发射极电压 Gate emitter voltage		V_{GE}	± 20	V

特征值 / Characteristic Values

Parameter	Conditions	Symbol	Value			Unit
			Min.	Typ.	Max.	
集电极-发射极饱和电压 Collector-Emitter saturation voltage	$V_{GE} = 15V$, $I_C = 40A$ $V_{GE} = 15V$, $I_C = 40A$ $V_{GE} = 15V$, $I_C = 40A$	$T_{vj} = 25^{\circ}C$ $T_{vj} = 125^{\circ}C$ $T_{vj} = 150^{\circ}C$	V_{CESat}	1.73 2.02 2.04	2.15	V
栅极-发射极阈值电压 Gate-Emitter threshold voltage	$I_C = 1.5mA$, $V_{GE} = V_{CE}$	$T_{vj} = 25^{\circ}C$	$V_{GE(th)}$	5.00 5.60 6.20		
栅电荷 Gate charge	$V_{GE} = -15V \dots +15V$		Q_G	0.33		μC

内部栅极电阻 Internal gate resistor		R_{Gint}		None		Ω
输入电容 Input capacitance	$f=1\text{MHz}, V_{CE}=25\text{V}, V_{GE}=0\text{V}$ $T_{vj}=25^\circ\text{C}$	C_{ies}		2.72		nF
反向传输电容 Reverse transfer capacitance		C_{res}		0.14		
集电极-发射极截止电流 Collector-emitter cut-off current	$V_{CE}=1200\text{V}, V_{GE}=0\text{V}$ $T_{vj}=25^\circ\text{C}$	I_{CES}			1	mA
栅极-发射极漏电流 Gate-emitter leakage current	$V_{CE}=0\text{V}, V_{GE}=20\text{V}$ $T_{vj}=25^\circ\text{C}$	I_{GES}			100	nA
开通延迟时间 Turn-on delay time	$I_C=40\text{A}, V_{CE}=600\text{V}$ $V_{GE}=\pm 15\text{V}, R_G=20\Omega$ (电感负载) / (inductive load)	$T_{vj}=25^\circ\text{C}$ $T_{vj}=125^\circ\text{C}$ $T_{vj}=150^\circ\text{C}$	t_{don}		49	
					42	
					44	
上升时间 Rise time	$I_C=40\text{A}, V_{CE}=600\text{V}$ $V_{GE}=\pm 15\text{V}, R_G=20\Omega$ (电感负载) / (inductive load)	$T_{vj}=25^\circ\text{C}$ $T_{vj}=125^\circ\text{C}$ $T_{vj}=150^\circ\text{C}$	t_r		55	ns
					57	
					57	
关断延迟时间 Turn-off delay time	$I_C=40\text{A}, V_{CE}=600\text{V}$ $V_{GE}=\pm 15\text{V}, R_G=20\Omega$ (电感负载) / (inductive load)	$T_{vj}=25^\circ\text{C}$ $T_{vj}=125^\circ\text{C}$ $T_{vj}=150^\circ\text{C}$	t_{doff}		267	
					320	
					336	
下降时间 Fall time	$I_C=40\text{A}, V_{CE}=600\text{V}$ $V_{GE}=\pm 15\text{V}, R_G=20\Omega$ (电感负载) / (inductive load)	$T_{vj}=25^\circ\text{C}$ $T_{vj}=125^\circ\text{C}$ $T_{vj}=150^\circ\text{C}$	t_f		148	
					226	
					245	
开通损耗能量 (每脉冲) Turn-on energy loss per pulse	$I_C=40\text{A}, V_{CE}=600\text{V}$ $V_{GE}=\pm 15\text{V}, R_G=20\Omega$ (电感负载) / (inductive load)	$T_{vj}=25^\circ\text{C}$ $T_{vj}=125^\circ\text{C}$ $T_{vj}=150^\circ\text{C}$	E_{on}		3.47	mJ
					4.94	
					5.65	
关断损耗能量 (每脉冲) Turn-off energy loss per pulse	$I_C=40\text{A}, V_{CE}=600\text{V}$ $V_{GE}=\pm 15\text{V}, R_G=20\Omega$ (电感负载) / (inductive load)	$T_{vj}=25^\circ\text{C}$ $T_{vj}=125^\circ\text{C}$ $T_{vj}=150^\circ\text{C}$	E_{off}		2.07	
					2.92	
					3.17	
短路数据 SC data	$V_{GE}\leq 15\text{V}, V_{CC}=800\text{V}$ $V_{CEmax}=V_{CES}-L_{sCE}\cdot di/dt$ $t_p\leq 8\mu\text{s}, T_{vj}=150^\circ\text{C}$	I_{sc}			196	A
在开关状态下温度 Temperature under switching conditions		$T_{vj\ op}$	-40		150	$^\circ\text{C}$

二极管, 逆变器 / Diode, Inverter

最大额定值 / Maximum Ratings

Parameter	Conditions	Symbol	Value	Unit
反向重复峰值电压 Repetitive peak reverse voltage	$T_{vj}=25^\circ\text{C}$	V_{RRM}	1200	V
连续正向直流电流 Continuous DC forward current		I_F	30	A
正向重复峰值电流 Repetitive peak forward current	$t_p=1\text{ms}$	I_{FRM}	60	A
I^2t 值 I^2t -value	$t_p=10\text{ms}, \sin 180^\circ, T_{vj}=125^\circ\text{C}$	I^2t	1560	A^2s

特征值 / Characteristic Values

Parameter	Conditions	Symbol	Value			Unit
			Min.	Typ.	Max.	
正向电压 Forward voltage	$I_F=30A, V_{GE}=0V$ $I_F=30A, V_{GE}=0V$ $I_F=30A, V_{GE}=0V$	$T_{vj}=25^{\circ}C$ $T_{vj}=125^{\circ}C$ $T_{vj}=150^{\circ}C$	V_F	2.05 1.71 1.61	2.60	V
反向恢复峰值电流 Peak reverse recovery current	$I_F=30A,$ $-di_F/dt=632A/\mu s(T_{vj}=150^{\circ}C)$ $V_R=600V, V_{GE}=-15V$	$T_{vj}=25^{\circ}C$ $T_{vj}=125^{\circ}C$ $T_{vj}=150^{\circ}C$	I_{RM}	28 43 47		A
恢复电荷 Recovered charge	$I_F=30A,$ $-di_F/dt=632A/\mu s(T_{vj}=150^{\circ}C)$ $V_R=600V, V_{GE}=-15V$	$T_{vj}=25^{\circ}C$ $T_{vj}=125^{\circ}C$ $T_{vj}=150^{\circ}C$	Q_F	2.39 5.90 7.21		μC
反向恢复损耗（每脉冲） Reverse recovered energy	$I_F=30A,$ $-di_F/dt=632A/\mu s(T_{vj}=150^{\circ}C)$ $V_R=600V, V_{GE}=-15V$	$T_{vj}=25^{\circ}C$ $T_{vj}=125^{\circ}C$ $T_{vj}=150^{\circ}C$	E_{rec}	0.81 1.99 2.42		mJ
在开关状态下温度 Temperature under switching conditions			$T_{vj op}$	-40	150	$^{\circ}C$

二极管，整流器 / Diode, Rectifier

最大额定值 / Maximum Ratings

Parameter	Conditions	Symbol	Value	Unit
反向重复峰值电压 Repetitive peak reverse voltage	$T_{vj}=25^{\circ}C$	V_{RRM}	1600	V
反向不重复峰值电压 Non-Repetitive peak reverse voltage	$T_{vj}=25^{\circ}C, I_{RRM}=5\mu A$	V_{RSM}	2000	V
最大正向平均电流 Maximum Average Forward Current		$I_{F(AV)}$	30	A
正向浪涌电流 Surge forward current	$t_p=10ms, \sin 180^{\circ}, T_{vj}=25^{\circ}C$	I_{FSM}	360	A
I^2t 值 I^2t -value	$t_p=10ms, \sin 180^{\circ}, T_{vj}=125^{\circ}C$	I^2t	648	A^2s

特征值 / Characteristic Values

Parameter	Conditions	Symbol	Value			Unit
			Min.	Typ.	Max.	
正向电压 Forward voltage	$I_F=30A, T_j=25^{\circ}C$	V_F			1.2	V
反向电流 Reverse current	$V_R=V_{RRM}$ $T_{vj}=25^{\circ}C$	I_R			5	μA
在开关状态下温度 Temperature under switching conditions			$T_{vj op}$	-40	150	$^{\circ}C$

IGBT, 制动-斩波器 / IGBT, Brake-Chopper**最大额定值 / Maximum Ratings**

Parameter	Conditions	Symbol	Value	Unit
集电极-发射极电压 Collector-Emitter voltage	$T_{vj}=25^{\circ}\text{C}$	V_{CES}	1200	V
连续集电极直流电流 Continuous DC collector current	$T_C=100^{\circ}\text{C}, T_{vj\max}=175^{\circ}\text{C}$	$I_{C\text{nom}}$	25	A
集电极重复峰值电流 Repetitive peak collector current	$t_p=1\text{ms}$	I_{CRM}	50	A
栅极-发射极电压 Gate emitter voltage		V_{GE}	± 20	V

特征值 / Characteristic Values

Parameter	Conditions	Symbol	Value			Unit
			Min.	Typ.	Max.	
集电极-发射极饱和电压 Collector-Emitter saturation voltage	$V_{GE}=15\text{V}, I_C=25\text{A}$ $V_{GE}=15\text{V}, I_C=25\text{A}$ $V_{GE}=15\text{V}, I_C=25\text{A}$	$T_{vj}=25^{\circ}\text{C}$ $T_{vj}=125^{\circ}\text{C}$ $T_{vj}=150^{\circ}\text{C}$	V_{CESat}	1.97 2.20 2.26	2.40	V
栅极-发射极阈值电压 Gate-Emitter threshold voltage	$I_C=1\text{mA}, V_{GE}=V_{CE}$	$T_{vj}=25^{\circ}\text{C}$	$V_{GE(th)}$	5.10	5.70	6.30
栅电荷 Gate charge	$V_{GE}=-15\text{V}\dots+15\text{V}$		Q_G	0.18		μC
内部栅极电阻 Internal gate resistor			R_{Gint}	None		Ω
输入电容 Input capacitance	$f=1\text{MHz}, V_{CE}=25\text{V}, V_{GE}=0\text{V}$	$T_{vj}=25^{\circ}\text{C}$	C_{ies}	1.65		nF
反向传输电容 Reverse transfer capacitance			C_{res}	0.08		
集电极-发射极截止电流 Collector-emitter cut-off current	$V_{CE}=1200\text{V}, V_{GE}=0\text{V}$	$T_{vj}=25^{\circ}\text{C}$	I_{CES}		1	mA
栅极-发射极漏电流 Gate-emitter leakage current	$V_{CE}=0\text{V}, V_{GE}=20\text{V}$	$T_{vj}=25^{\circ}\text{C}$	I_{GES}		100	nA
开通延迟时间 Turn-on delay time	$I_C=25\text{A}, V_{CE}=600\text{V}$ $V_{GE}=\pm 15\text{V}, R_G=68\Omega$ (电感负载) / (inductive load)	$T_{vj}=25^{\circ}\text{C}$ $T_{vj}=125^{\circ}\text{C}$ $T_{vj}=150^{\circ}\text{C}$	t_{don}	112 97 96		ns
上升时间 Rise time	$I_C=25\text{A}, V_{CE}=600\text{V}$ $V_{GE}=\pm 15\text{V}, R_G=68\Omega$ (电感负载) / (inductive load)	$T_{vj}=25^{\circ}\text{C}$ $T_{vj}=125^{\circ}\text{C}$ $T_{vj}=150^{\circ}\text{C}$	t_r	96 102 105		
关断延迟时间 Turn-off delay time	$I_C=25\text{A}, V_{CE}=600\text{V}$ $V_{GE}=\pm 15\text{V}, R_G=68\Omega$ (电感负载) / (inductive load)	$T_{vj}=25^{\circ}\text{C}$ $T_{vj}=125^{\circ}\text{C}$ $T_{vj}=150^{\circ}\text{C}$	t_{doff}	422 460 470		
下降时间 Fall time	$I_C=25\text{A}, V_{CE}=600\text{V}$ $V_{GE}=\pm 15\text{V}, R_G=68\Omega$ (电感负载) / (inductive load)	$T_{vj}=25^{\circ}\text{C}$ $T_{vj}=125^{\circ}\text{C}$ $T_{vj}=150^{\circ}\text{C}$	t_f	187 262 282		
开通损耗能量 (每脉冲) Turn-on energy loss per pulse	$I_C=25\text{A}, V_{CE}=600\text{V}$ $V_{GE}=\pm 15\text{V}, R_G=68\Omega$	$T_{vj}=25^{\circ}\text{C}$ $T_{vj}=125^{\circ}\text{C}$	E_{on}	3.75 4.67		mJ

	(电感负载) / (inductive load)	$T_{vj}=150^{\circ}\text{C}$			5.02		
关断损耗能量 (每脉冲) Turn-off energy loss per pulse	$I_C=25\text{A}, V_{CE}=600\text{V}$	$T_{vj}=25^{\circ}\text{C}$	E_{off}		1.83		
	$V_{GE}=\pm 15\text{V}, R_G=68\Omega$	$T_{vj}=125^{\circ}\text{C}$			2.28		
	(电感负载) / (inductive load)	$T_{vj}=150^{\circ}\text{C}$			2.45		
在开关状态下温度 Temperature under switching conditions			$T_{vj\text{ op}}$	-40		150	$^{\circ}\text{C}$

二极管, 制动-斩波器 / Diode, Brake-Chopper

最大额定值 / Maximum Ratings

Parameter	Conditions	Symbol	Value	Unit
反向重复峰值电压 Repetitive peak reverse voltage	$T_{vj}=25^{\circ}\text{C}$	V_{RRM}	1200	V
连续正向直流电流 Continuous DC forward current		I_F	15	A
正向重复峰值电流 Repetitive peak forward current	$t_p=1\text{ms}$	I_{FRM}	30	A
I^2t 值 I^2t -value	$t_p=10\text{ms}, \sin 180^{\circ}, T_{vj}=125^{\circ}\text{C}$	I^2t	120	A^2s

特征值 / Characteristic Values

Parameter	Conditions	Symbol	Value			Unit
			Min.	Typ.	Max.	
正向电压 Forward voltage	$I_F=15\text{A}, V_{GE}=0\text{V}$ $I_F=15\text{A}, V_{GE}=0\text{V}$ $I_F=15\text{A}, V_{GE}=0\text{V}$	$T_{vj}=25^{\circ}\text{C}$ $T_{vj}=125^{\circ}\text{C}$ $T_{vj}=150^{\circ}\text{C}$	V_F	2.32 1.80 1.69	2.70	V
反向恢复峰值电流 Peak reverse recovery current	$I_F=15\text{A},$ $-di_F/dt=189\text{A}/\mu\text{s}(T_{vj}=150^{\circ}\text{C})$ $V_R=600\text{V}, V_{GE}=-15\text{V}$	$T_{vj}=25^{\circ}\text{C}$ $T_{vj}=125^{\circ}\text{C}$ $T_{vj}=150^{\circ}\text{C}$	I_{RM}	8 12 14		A
恢复电荷 Recovered charge	$I_F=15\text{A},$ $-di_F/dt=189\text{A}/\mu\text{s}(T_{vj}=150^{\circ}\text{C})$ $V_R=600\text{V}, V_{GE}=-15\text{V}$	$T_{vj}=25^{\circ}\text{C}$ $T_{vj}=125^{\circ}\text{C}$ $T_{vj}=150^{\circ}\text{C}$	Q_f	1.25 2.75 3.58		μC
反向恢复损耗 (每脉冲) Reverse recovered energy	$I_F=15\text{A},$ $-di_F/dt=189\text{A}/\mu\text{s}(T_{vj}=150^{\circ}\text{C})$ $V_R=600\text{V}, V_{GE}=-15\text{V}$	$T_{vj}=25^{\circ}\text{C}$ $T_{vj}=125^{\circ}\text{C}$ $T_{vj}=150^{\circ}\text{C}$	E_{rec}	0.40 0.90 1.21		mJ
在开关状态下温度 Temperature under switching conditions			$T_{vj\text{ op}}$	-40	150	$^{\circ}\text{C}$

负温度系数热敏电阻 / NTC-Thermistor

特征值 / Characteristic Values

Parameter	Conditions	Symbol	Value			Unit
			Min.	Typ.	Max.	
额定电阻值 Rated resistances	$T_c=25^{\circ}\text{C}$, $\pm 5\%$	R_{25}		5.0		$\text{K}\Omega$
B-值 B-value	$\pm 2\%$	$B_{25/50}$		3375		K

模块 / Module

Parameter	Conditions	Symbol	Value			Unit
绝缘测试电压 Isolation test voltage	RMS, $f=50\text{Hz}$, $t=1\text{min}$	V_{ISOL}	2500			V
内部绝缘 Internal isolation			Al_2O_3			
储存温度 Storage temperature		T_{stg}	-40		125	$^{\circ}\text{C}$
模块安装的扭矩 Mounting torque for modul mounting		M	3.0		6.0	Nm
重量 Weight		W		42		g



图 1. 典型输出特性 ($V_{GE}=15V$)
Figure 1. Typical output characteristics ($V_{GE}=15V$)



图 2. 典型输出特性 ($T_{vj}=150^{\circ}C$)
Figure 2. Typical output characteristics ($T_{vj}=150^{\circ}C$)

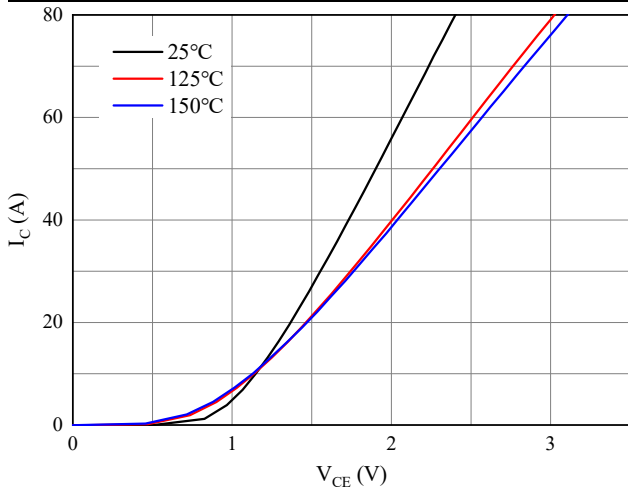

图 3. 典型传输特性 ($V_{CE}=20V$)
Figure 3. Typical transfer characteristic ($V_{CE}=20V$)

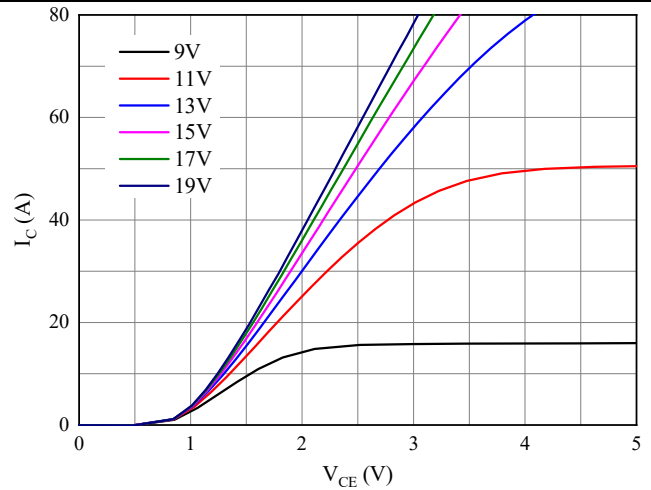

图 4. 正向偏压特性 二极管
Figure 4. Forward characteristic of Diode

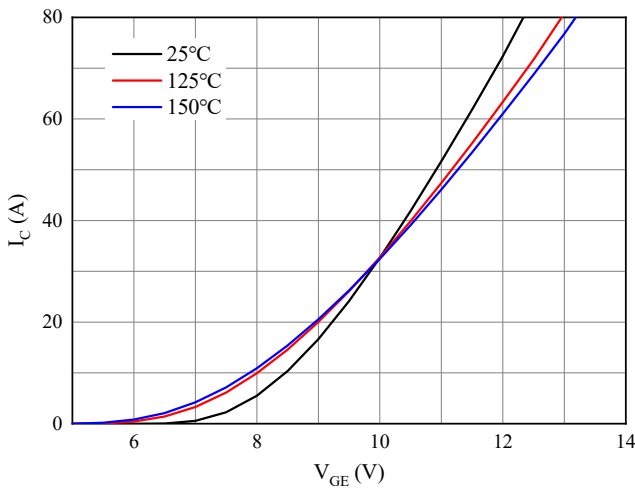

图 5. 开关损耗 逆变器
Figure 5. Switching losses of IGBT
 $V_{GE}=\pm 15V, R_{Gon}=20\Omega, R_{Goff}=20\Omega, V_{CE}=600V$

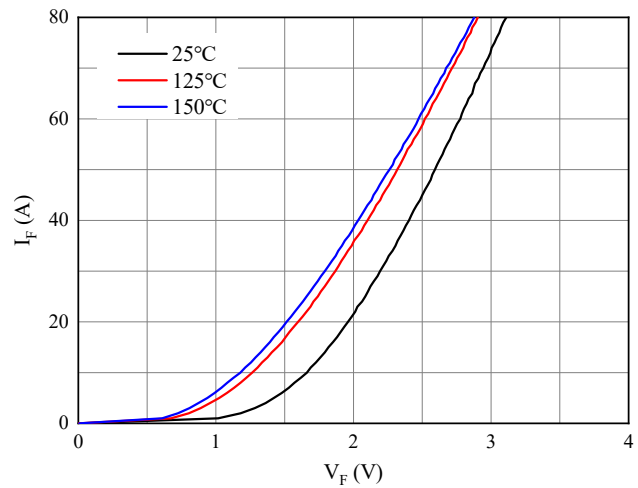

图 6. 开关损耗 逆变器
Figure 6. Switching losses of IGBT
 $V_{GE}=\pm 15V, I_C=40A, V_{CE}=600V$

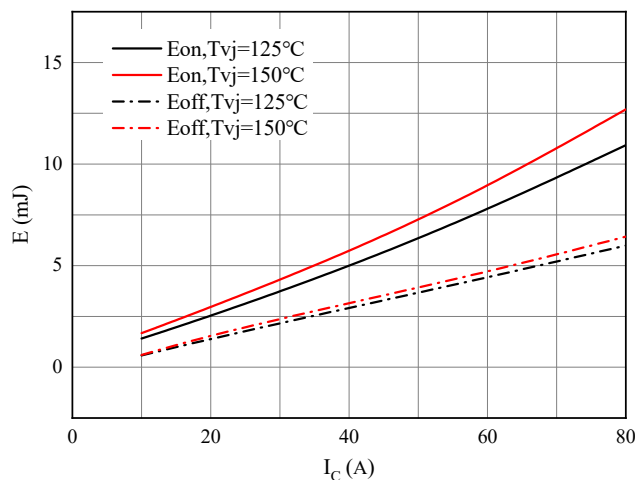

图 7. 开关损耗 二极管
Figure 7. Switching losses of Diode
R_{Gon}=68Ω, V_{CE}=600V

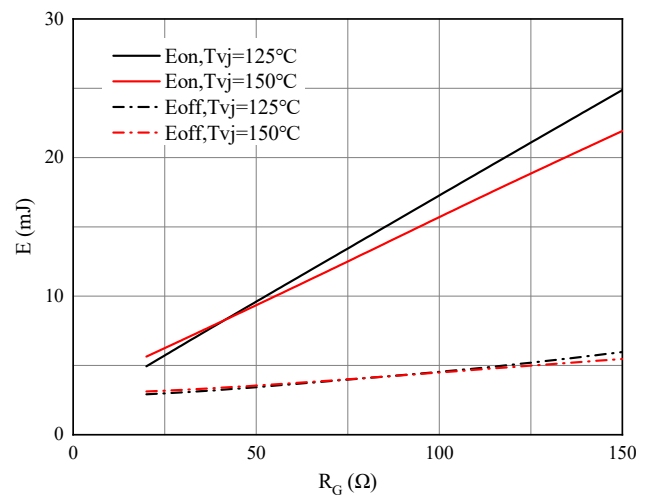

图 8. 开关损耗 二极管
Figure 8. Switching losses of Diode
I_F=30A, V_{CE}=600V

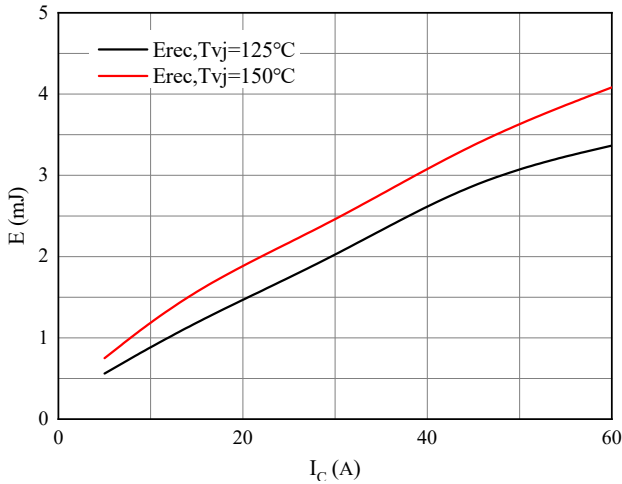

图 9. 电容特性
Figure 9. Capacitance characteristic

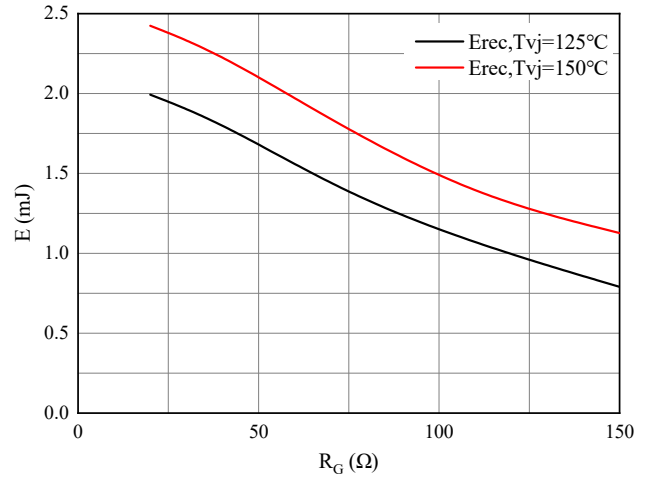

图 10. 负温系数热敏电阻 温度特性
Figure 10. NTC-Themistor-temperature characteristic

接线图 / Circuit diagram

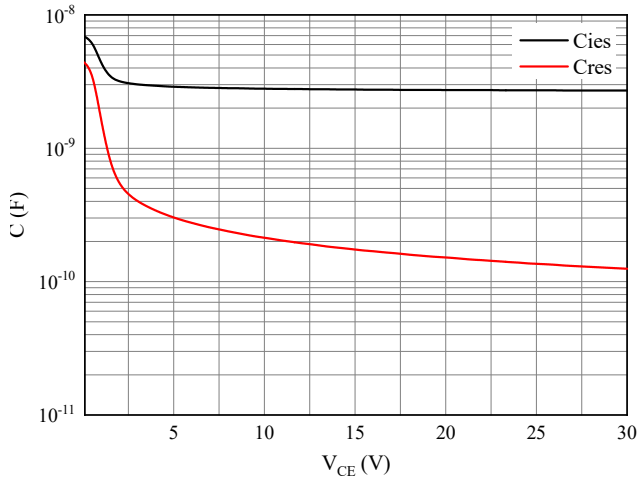

封装尺寸 / Package outlines

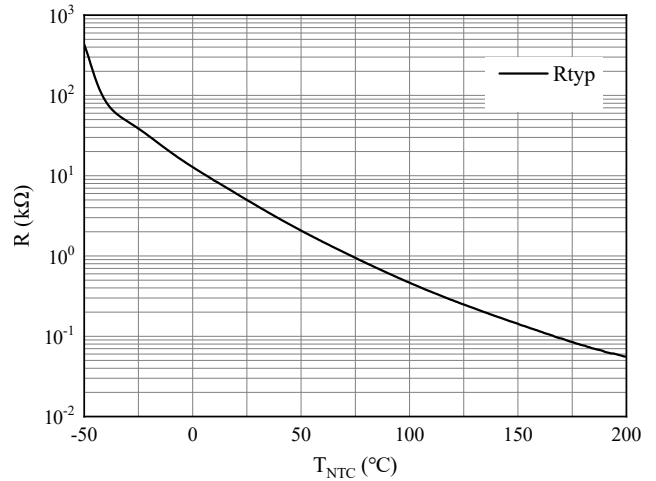
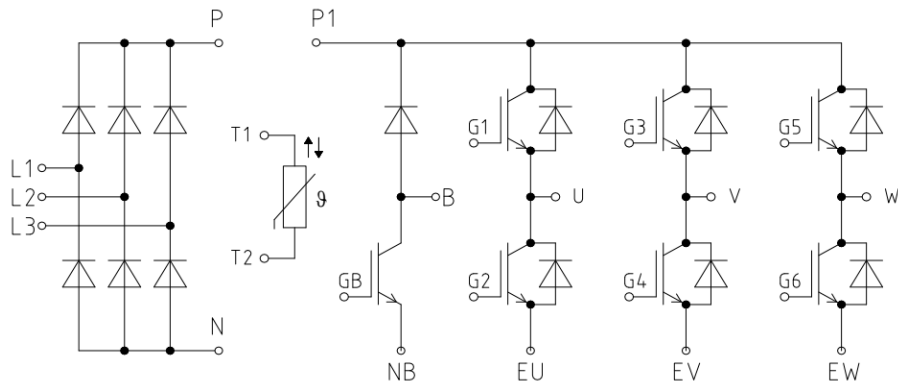